

Economizer Fan

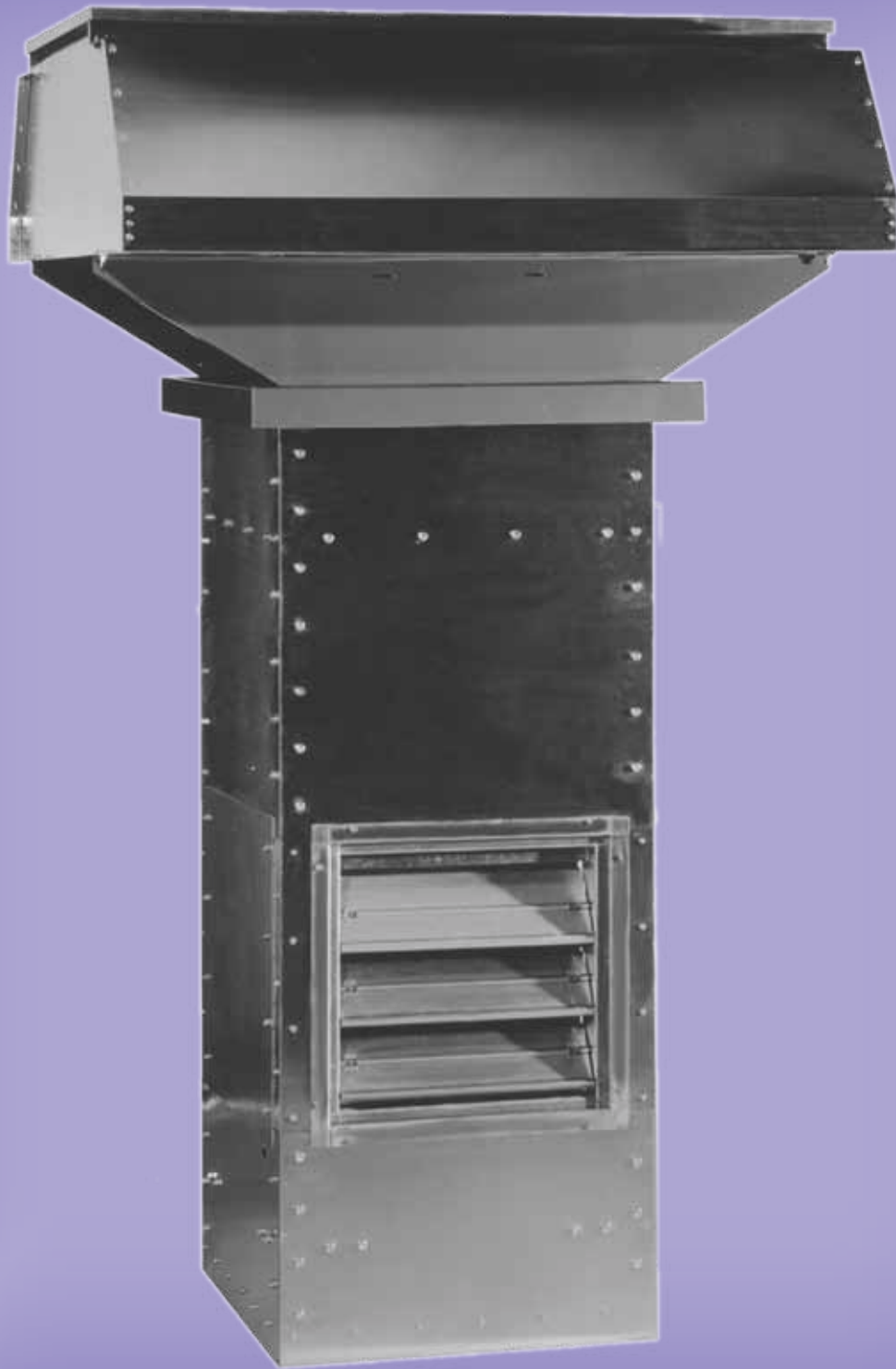

Economizer Fan

Hooded Propeller Fans with Mix, Recirculate, Supply and Exhaust Modes



Introduction & Construction Features	2
Operation Modes	2
Specification and Dimension Data	
MRS-D	3
MRSF-D	4
MRSE-D	5
Accessories	6
Performance Data	
MRS-D	7
Selection Information	
MRSF-D	7
Performance Data	
MRSE-D	8

Introduction & Construction Features

Building ventilation requirements are often dictated by changes in the outside air temperature, production processes within a facility and / or occupancy within a facility. Loren Cook Company's Economizer Fan offers the flexibility to maintain comfortable temperatures in factories, gymnasiums, equipment rooms, warehouses, manufacturing plants or other facilities with a high internal heat load. The mixing of cool outside air with warm inside air, "free cooling," provides a more comfortable air temperature to any facility. It is the fan's most economical function. The Economizer Fan can also recirculate inside air, supply cool outside air to a facility, or exhaust warm or contaminated air.



MRS-D
MRSF-D
MRSE-D

- Steel curb cap with continuously welded corners and Lorenized™ fan finish.
- 14 gauge galvanized steel plenum with two access doors.
- Heavy duty galvanized steel control dampers.
- Galvanized steel hood.
- Bird screen.
- Corrosion resistant fasteners.
- Heavy duty steel power assembly with extruded aluminum propeller.

Operation Modes

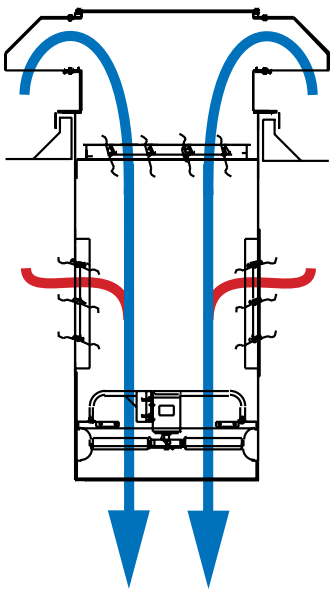

Mix
Cool outside air is mixed with warm inside air to provide more comfortable building temperatures.

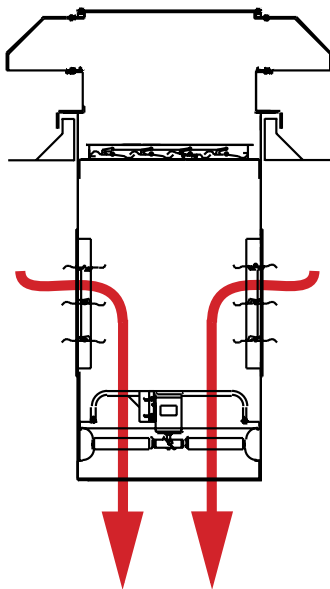

Recirculation
Warm inside air at roof level is forced downward to reduce heating costs.

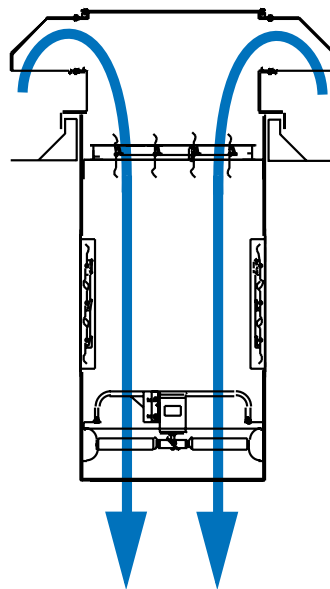

Supply
Cool outside air is supplied into the building to reduce cooling costs.

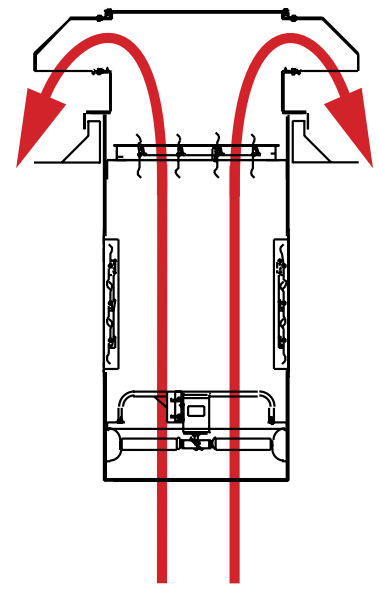

Exhaust
Warm or contaminated inside air is exhausted from the building.

Typical Specifications and Dimensions

MRS-D: Mix-Recirculate-Supply Prop. Roof Fan



- Description - Fan shall be hooded, roof mounted, direct driven, propeller economizer fan.
- Operation Modes - Mix outside air with recirculated air, recirculate inside air, supply outside air.
- Certification - Fan shall be manufactured at an ISO 9001 certified facility. Fan shall be listed by Underwriters Laboratories (UL 705) and UL listed for Canada (cUL 705).
- Construction - The fan shall be of bolted and welded construction utilizing corrosion resistant fasteners. The hood shall be constructed of 18 gauge galvanized steel. The hood base shall be minimum 14 gauge Lorenized steel with continuously welded curb cap corners. The plenum shall be constructed of 14 gauge galvanized steel and provided with integral lifting lugs, propeller safety screen and two access doors. Outside air damper and recirculated air dampers shall be constructed of galvanized steel frame and blades. The motor shall be mounted to a minimum 14 gauge tubular steel power assembly. The propeller shall be located in a double venturi for efficient air flow in all modes of operation. Unit shall bear an engraved aluminum nameplate. Unit shall be shipped in ISTA certified transit tested packaging.
- Propeller - Propeller shall be extruded aluminum airfoil design with cast aluminum hub. The blade pitch shall be factory set and locked using set screws and roll pin. The hub shall be keyed and locked to the shaft utilizing two set screws or a taper lock bushing. Propeller shall be balanced in accordance with AMCA Standard 204-05, Balance Quality and Vibration Levels for Fans.
- Motor - Motor shall be Nema design B with class B insulation rated for continuous duty and furnished at the specified voltage, phase and enclosure.
- Product - Fan shall be model MRSE-D as manufactured by Loren Cook Company of Springfield, Missouri.



Type Economizer Fan is furnished standard with UL 705 and CUL listing (Power Ventilator/ZACT) when furnished with factory supplied motor.

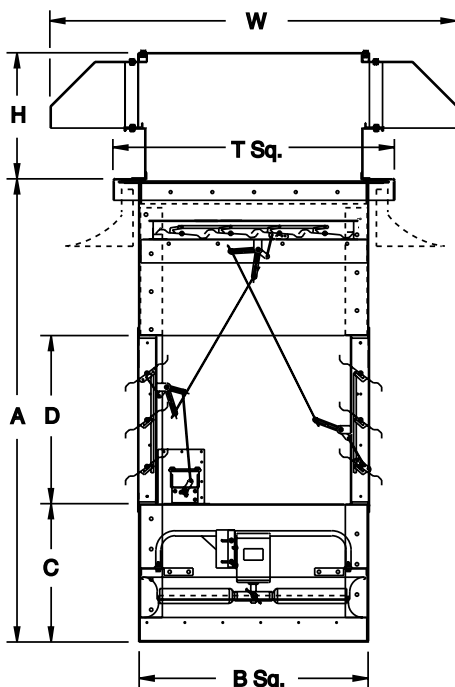

MRS-D Dimension Data

Size	A	B Sq.	C	D Sq.	H	W Sq.	T Sq.	Material Gauge			Roof Opening Square*	Approx. Ship Wt.-Lbs.
								Base	Hood	Plenum		
24	60-1/4	31-1/2	18	22-1/4	26	59	37-1/2	14	18	14	32-1/2	635
30	65-3/4	37-1/2	18	27-3/4	28	69	43-1/2	14	18	14	38-1/2	785
36	71-1/4	43-1/2	18	33-1/4	29	80	49-1/2	14	16	14	44-1/2	910
42	78-3/4	49-1/2	20	38-3/4	39	90	55-1/2	14	16	14	50-1/2	1125
48	84-1/4	55-1/2	20	44-1/4	39	90 x 110	61-1/2	14	16	14	56-1/2	1480
54**	89-3/4	61-1/2	20	49-3/4	42	109	67-1/2	14	18	14	62-1/2	1850

All dimensions in inches.

*Roof opening size for curbs supplied by Cook only.

**Sizes 54 require field assembly of hood.

Typical Specifications and Dimensions

MRSF-D: Mix-Recirculate-Filtered Supply Prop. Roof Fan



- Description - Fan shall be hooded, roof mounted, direct driven, filtered, propeller economizer fan.
- Operation Modes - Mix filtered outside air with recirculated air, recirculate inside air, supply filtered outside air.
- Certification - Fan shall be manufactured at an ISO 9001 certified facility. Fan shall be listed by Underwriters Laboratories (UL 705) and UL listed for Canada (cUL 705).
- Construction - The fan shall be of bolted and welded construction utilizing corrosion resistant fasteners. The hood shall be constructed of 18 gauge galvanized steel. Filters shall be washable, 2 inch thick aluminum mesh type. The hood base shall be minimum 14 gauge Lorenized steel with continuously welded curb cap corners. The plenum shall be constructed of 14 gauge galvanized steel and provided with integral lifting lugs, propeller safety screen and two access doors. Outside air damper and recirculated air dampers shall be constructed of galvanized steel frame and blades. The motor shall be mounted to a minimum 14 gauge tubular steel power assembly. The propeller shall be located in a double venturi for efficient air flow in all modes of operation. Unit shall bear an engraved aluminum nameplate. Nameplate shall indicate design CFM and static pressure. Unit shall be shipped in ISTA certified transit tested packaging.
- Propeller - Propeller shall be extruded aluminum airfoil design with cast aluminum hub. The blade pitch shall be factory set and locked using set screws and roll pin. The hub shall be keyed and locked to the shaft utilizing two set screws or a taper lock bushing. Propeller shall be balanced in accordance with AMCA Standard 204-05, Balance Quality and Vibration Levels for Fans.
- Motor - Motor shall be Nema design B with class B insulation rated for continuous duty and furnished at the specified voltage, phase and enclosure.
- Product - Fan shall be model MRSF-D as manufactured by Loren Cook Company of Springfield, Missouri.



Type Economizer Fan is furnished standard with UL 705 and CUL listing (Power Ventilator/ZACT) when furnished with factory supplied motor.

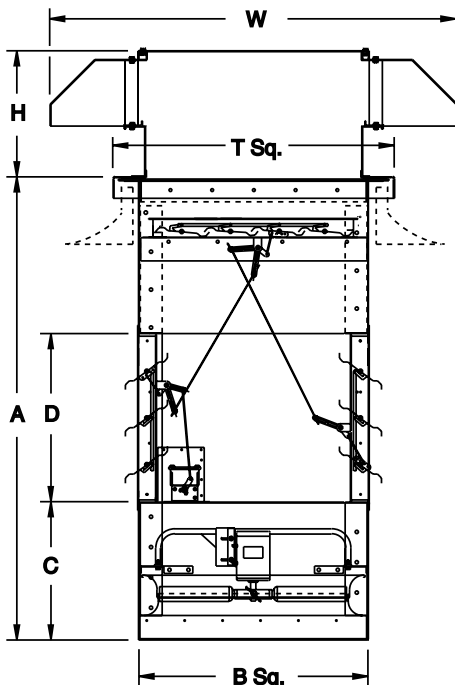

MRSF-D Dimension Data

Size	A	B Sq.	C	D Sq.	H	W Sq.	T Sq.	Material Gauge			Roof Opening Square*	Approx. Ship Wt.-Lbs.
								Base	Hood	Plenum		
24	60-1/4	31-1/2	18	22-1/4	26	69	37-1/2	14	18	14	32-1/2	635
30	65-3/4	37-1/2	18	27-3/4	28	80	43-1/2	14	18	14	38-1/2	785
36	71-1/4	43-1/2	18	33-1/4	29	90	49-1/2	14	16	14	44-1/2	910
42	78-3/4	49-1/2	20	38-3/4	39	90 x 110	55-1/2	14	16	14	50-1/2	1125
48**	84-1/4	55-1/2	20	44-1/4	39	109	61-1/2	14	16	14	56-1/2	1480
54**	89-3/4	61-1/2	20	49-3/4	42	119	67-1/2	14	18	14	62-1/2	1850

All dimensions in inches.

*Roof opening size for curbs supplied by Cook only.

**Sizes 48 and 54 require field assembly of hood.

Typical Specifications and Dimensions

MRSE-D: Mix-Recirculate-Supply-Exhaust Prop. Roof Fan



- Description - Fan shall be hooded, roof mounted, direct driven, propeller economizer fan.
- Operation Modes - Mix outside air with recirculated air, recirculate inside air, supply outside air, exhaust inside air.
- Certification - Fan shall be manufactured at an ISO 9001 certified facility. Fan shall be listed by Underwriters Laboratories (UL 705) and UL listed for Canada (cUL 705).
- Construction - The fan shall be of bolted and welded construction utilizing corrosion resistant fasteners. The hood shall be constructed of 18 gauge galvanized steel. The hood base shall be minimum 14 gauge Lorenized steel with continuously welded curb cap corners. The plenum shall be constructed of 14 gauge galvanized steel and provided with integral lifting lugs, propeller safety screen and two access doors. Outside air damper and recirculated air dampers shall be constructed of galvanized steel frame and blades. The motor shall be mounted to a minimum 14 gauge tubular steel power assembly. The propeller shall be located in a double venturi for efficient air flow in all modes of operation. Unit shall bear an engraved aluminum nameplate. Nameplate shall indicate design CFM and static pressure. Unit shall be shipped in ISTA certified transit tested packaging.
- Propeller - Propeller shall be a reversible, extruded aluminum airfoil design with cast aluminum hub. The blade pitch shall be factory set and locked using set screws and roll pin. The hub shall be keyed and locked to the shaft utilizing two set screws or a taper lock bushing. Propeller shall be balanced in accordance with AMCA Standard 204-05, Balance Quality and Vibration Levels for Fans.
- Motor - Motor shall be Nema design B with class B insulation rated for continuous duty and furnished at the specified voltage, phase and enclosure.
- Product - Fan shall be model MRSE-D as manufactured by Loren Cook Company of Springfield, Missouri.



Type Economizer Fan is furnished standard with UL 705 and CUL listing (Power Ventilator/ZACT) when furnished with factory supplied motor.

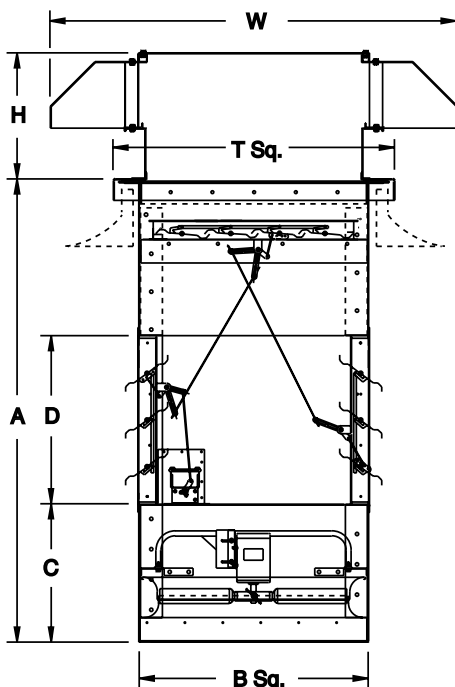

MRSE-D Dimension Data

Size	A	B Sq.	C	D Sq.	H	W Sq.	T Sq.	Material Gauge			Roof Opening Square*	Approx. Ship Wt.-Lbs.
								Base	Hood	Plenum		
24	60-1/4	31-1/2	18	22-1/4	26	59	37-1/2	14	18	14	32-1/2	635
30	65-3/4	37-1/2	18	27-3/4	28	69	43-1/2	14	18	14	38-1/2	785
36	71-1/4	43-1/2	18	33-1/4	29	80	49-1/2	14	16	14	44-1/2	910
42	78-3/4	49-1/2	20	38-3/4	39	90	55-1/2	14	16	14	50-1/2	1125
48	84-1/4	55-1/2	20	44-1/4	39	90 x 110	61-1/2	14	16	14	56-1/2	1480
54**	89-3/4	61-1/2	20	49-3/4	42	109	67-1/2	14	18	14	62-1/2	1850

All dimensions in inches.

*Roof opening size for curbs supplied by Cook only.

**Sizes 48 and 54 require field assembly of hood.

Accessories

Four-Way Outlet Diffuser



This diffuser is mounted to the bottom of the plenum to provide improved air distribution. The diffuser is constructed of 18 gauge steel and is coated with Cook's Lorenized™ fan finish.

Disconnect Switches

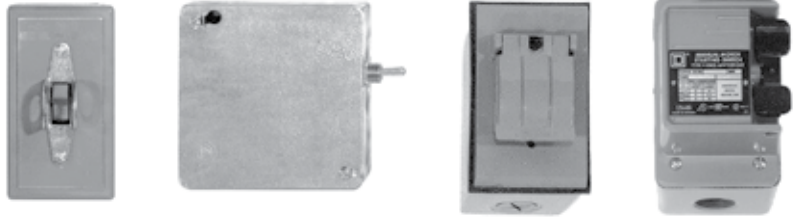

- NEMA 1 (Lockable) - Indoor, general purpose with lockable switch.
- NEMA 1 - Indoor, general purpose.
- NEMA 3R - Exterior mount, weather resistant.
- NEMA 4 - Water tight, dust tight.

Control Panel

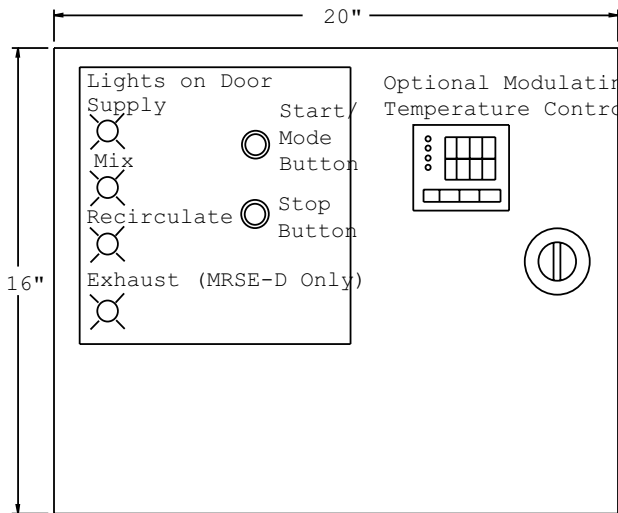

The optional remote mounted Economizer Control Panel allows fan operation and mode selection to be controlled from a convenient floor level location. All control components, including starters, are enclosed in a NEMA 1 cabinet with exterior start, stop and mode selection buttons. The model MRS/MRSF control panel allows for selection of the mix, recirculate, and supply modes. The model MRSE panel allows for selection of the mix, recirculate, supply and exhaust modes.

Wiring Requirements - Each panel requires 110V (5A) input for controls operation and a fused motor input. The output of each panel includes the motor circuit and three-wire damper control. A temperature probe connection is required with the optional modulating temperature control package.

Optional Modulating Temperature Control Package - This optional package for the control panels above, allows the outlet temperature to be selected when in mix mode. In mix mode, the temperature controller allows an operator to set a target outlet temperature for the fan. The controller reads the fan outlet temperature from a field-mounted, three-wire RTD (included) and modulates the dampers to produce an outlet temperature equal to the target temperature.

Curb

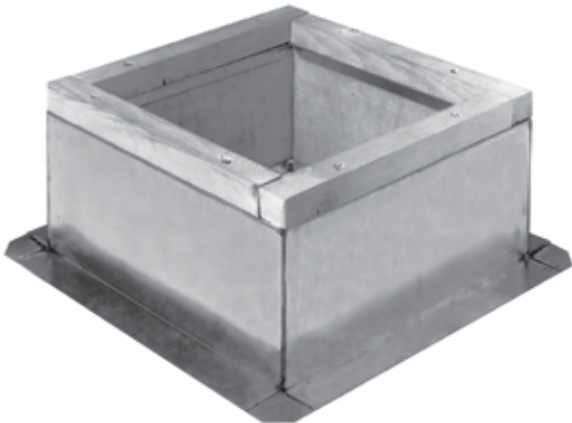

- 18 gauge galvanized steel (RCG) or .080 aluminum (RCA).
- 1-1/2", 3 lbs. density thermal and acoustical insulation.
- Continuously welded corners.
- Wood nailer.
- Options
- No wood nailer (deduct 1-1/2" from height).
- 13-1/2" tall construction.

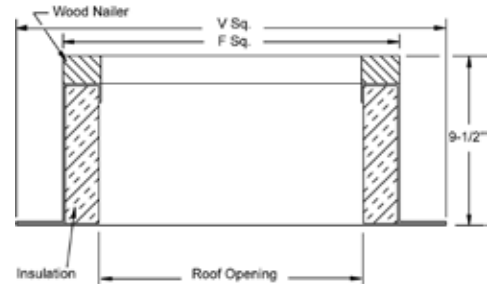

Additional Accessories

- Aluminum hood and roof base
- Insulated low leakage top damper
- Cabinet extensions - 12" and 24"

Pre-Fabricated Curb Dimension Data

Unit	RCG	F Sq.	V Sq.	Roof Opening	Approx. Ship Wt.-Lbs.
24	RCG-35	35-1/2	39-1/2	32-1/2	43
30	RCG-41	41-1/2	45-1/2	38-1/2	50
36	RCG-47	47-1/2	51-1/2	44-1/2	85
42	RCG-53	53-1/2	57-1/2	50-1/2	96
48	RCG-59	59-1/2	63-1/2	56-1/2	106
54	RCG-65	65-1/2	69-1/2	62-1/2	116

All dimensions in inches.

Performance Data

MRS-D

Fan Size	Catalog Number	RPM	Motor HP	FA Sones	Static Pressure											
					0"		.100"		.125"		.25"		.375"		.500"	
					CFM	BHP	CFM	BHP	CFM	BHP	CFM	BHP	CFM	BHP	CFM	BHP
24	24MRS418D	1140	1/3	18.2	4736	0.30	4283	0.32	4158	0.32	3447	0.35	2534	0.33	-	-
	24MRS426D	1140	1/2	19.5	6002	0.55	5498	0.56	5384	0.56	4738	0.57	3567	0.54	2218	0.50
	24MRS628D	1140	3/4	26.0	6481	0.76	6088	0.76	5989	0.77	5455	0.81	4652	0.83	3745	0.81
	24MRS418D	1725	1	36.0	7167	1.04	6879	1.06	6805	1.07	6412	1.10	5984	1.14	5513	1.18
	24MRS422D	1725	1-1/2	34.0	8114	1.46	7731	1.48	7649	1.49	7275	1.51	6915	1.54	6513	1.57
	24MRS428D	1725	2	40.0	9498	2.15	9138	2.17	9055	2.18	8654	2.19	8257	2.19	7827	2.19
30	30MRS422D	860	1/2	21.0	7804	0.54	6971	0.56	6792	0.57	5571	0.58	3603	0.53	2125	0.51
	30MRS428D	860	3/4	23.0	9136	0.80	8295	0.81	8098	0.81	6787	0.81	4643	0.75	-	-
	30MRS628D	860	1	30.0	9433	0.97	8784	0.98	8618	0.99	7694	1.06	6242	1.07	-	-
	30MRS414D	1140	3/4	26.0	7822	0.69	7222	0.71	7084	0.72	6384	0.77	5467	0.78	4321	0.77
	30MRS420D	1140	1	27.0	9852	1.07	9265	1.14	9120	1.15	8371	1.18	7476	1.18	6314	1.18
	30MRS426D	1140	1-1/2	29.0	11580	1.63	10925	1.66	10778	1.66	10068	1.69	9256	1.70	7819	1.66
36	36MRS432D	1140	2	39.0	12901	2.23	12399	2.24	12261	2.24	11471	2.26	10424	2.26	8986	2.19
	36MRS414D	860	3/4	25.0	10114	0.72	9175	0.76	8957	0.77	7772	0.82	6070	0.82	4025	0.76
	36MRS616D	860	1	23.0	10910	1.06	10194	1.12	10026	1.13	9167	1.19	7981	1.24	6071	1.16
	36MRS424D	860	1-1/2	26.0	14242	1.53	13219	1.55	12991	1.56	11841	1.62	10039	1.60	7910	1.54
	36MRS412D	1140	1-1/2	33.0	11936	1.36	11150	1.41	10973	1.42	10127	1.48	9211	1.51	8063	1.53
	36MRS416D	1140	2	35.0	14494	1.92	13755	2.06	13578	2.08	12714	2.12	11832	2.12	10826	2.16
42	42MRS618D	680	1-1/2	21.0	14849	1.28	13935	1.38	13660	1.40	11968	1.46	10219	1.52	7009	1.33
	42MRS624D	680	2	24.0	17498	1.98	16477	2.03	16178	2.05	14265	2.18	12164	2.22	10507	2.15
	42MRS632D	680	3	34.0	20611	3.20	19739	3.30	19466	3.31	17296	3.33	14227	3.27	12135	3.09
	42MRS414D	860	1-1/2	33.0	15398	1.49	14244	1.50	13951	1.51	12468	1.59	11012	1.62	8994	1.60
	42MRS614D	860	2	30.0	15681	1.89	15129	1.93	14973	1.94	14031	1.99	12737	2.06	11236	2.21
	42MRS424D	860	3	35.0	20743	3.05	19665	3.16	19373	3.18	17759	3.20	15829	3.19	12851	3.05
48	42MRS420D	1140	5	47.0	24689	5.42	23686	5.38	23467	5.39	22459	5.48	21510	5.61	20542	5.76
	48MRS616D	680	2	27.0	20087	2.08	18754	2.14	18453	2.17	16989	2.31	15339	2.43	13069	2.44
	48MRS620D	680	3	31.0	23490	2.88	22508	3.06	22234	3.10	20644	3.26	18608	3.34	16425	3.40
	48MRS414D	860	3	42.0	22908	2.88	21596	2.89	21263	2.90	19580	3.01	17881	3.13	16226	3.14
	48MRS422D	860	5	45.0	29684	5.37	28492	5.49	28192	5.51	26654	5.61	24980	5.68	22909	5.71
	48MRS624D	860	7-1/2	45.0	32923	7.77	32058	7.84	31827	7.87	30558	8.03	29051	8.25	27211	8.49
54	48MRS416D	1140	7-1/2	63.0	32225	7.71	31126	7.76	30875	7.78	29710	7.89	28618	8.01	27544	8.15
	48MRS420D	1140	10	61.0	36731	10.51	35555	10.43	35294	10.44	34092	10.53	32984	10.70	31904	10.91
	54MRS416D	680	3	32.0	27298	2.94	25377	2.99	24957	3.01	22918	3.13	20467	3.22	17153	3.19
	54MRS424D	680	5	37.0	34655	5.25	32907	5.44	32436	5.47	29837	5.50	26740	5.48	22068	5.30
	54MRS414D	860	5	46.0	32533	5.17	31062	5.16	30690	5.18	28808	5.31	26904	5.50	25010	5.63
	54MRS420D	860	7-1/2	51.0	39352	8.10	37659	8.04	37291	8.06	35592	8.21	33980	8.43	32306	8.65
54MRS424D	860	10	55.0	43828	10.62	42476	10.89	42123	10.94	40250	11.11	38176	11.14	35855	11.09	

MRSF-D Selection Information

Use the tables to determine the additional pressure drop from the filters. Add this to the building static pressure and use the MRS-D performance data.

$$\text{Filter Intake Velocity} = \frac{\text{Fan CFM}}{\text{Intake Area}}$$

Fan Intake Area

Fan Model MRSF-D	Intake Area (SF)
24	21.5
30	28.75
36	36
42	44.5
48	55
54	65.5

Filter Media Pressure Drop

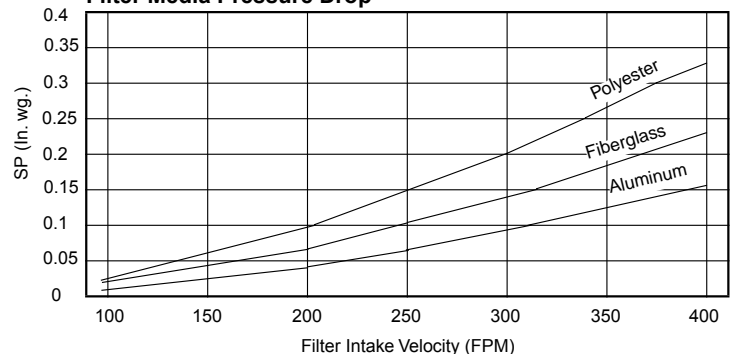

Performance Data

MRSE-D

Fan Size	Catalog Number	RPM	Motor HP	FA Sones	Static Pressure											
					0"		.100"		.125"		.25"		.375"		.500"	
					CFM	BHP	CFM	BHP	CFM	BHP	CFM	BHP	CFM	BHP	CFM	BHP
24	24MRSE616D	1140	1/3	21	3670	.24	3168	.27	3052	.27	2306	.30	1654	.33	-	-
	24MRSE428D	1140	1/2	21	5185	.45	4450	.47	4224	.47	3215	.50	2516	.56	-	-
	24MRSE434D	1140	3/4	29	5717	.58	4978	.59	4737	.59	3643	.63	2972	.72	2057	.79
	24MRSE618D	1725	1	46	5934	.92	5639	.95	5560	.96	5141	1.04	4699	1.13	4264	1.18
	24MRSE624D	1725	1-1/2	47	7513	1.49	7212	1.53	7130	1.54	6685	1.60	6167	1.67	5595	1.76
	24MRSE630D	1725	2	56	8510	2.10	8210	2.15	8126	2.16	7647	2.25	7047	2.35	6410	2.39
30	30MRSE422D	860	1/2	21	6387	.38	5344	.42	5037	.43	3607	.49	2114	.55	-	-
	30MRSE418D	1140	3/4	28	7357	.72	6631	.71	6426	.72	5352	.83	4258	.88	-	-
	30MRSE620D	1140	1	34	8225	.94	7759	.98	7616	1.00	6683	1.12	5670	1.19	4769	1.23
	30MRSE624D	1140	1-1/2	36	9608	1.29	9023	1.34	8859	1.36	7923	1.45	6824	1.55	5793	1.58
	30MRSE630D	1140	2	42	10883	1.82	10293	1.89	10120	1.91	9055	2.04	7792	2.07	6669	2.13
36	36MRSE416D	860	3/4	22	8608	.54	7391	.61	7087	.63	5324	.71	3670	.76	-	-
	36MRSE420D	860	1	26	10273	.83	9158	.86	8824	.90	7080	1.02	5370	1.05	3538	1.19
	36MRSE426D	860	1-1/2	28	12456	1.24	11375	1.35	10902	1.36	8854	1.42	6990	1.56	5451	1.68
	36MRSE420D	1140	2	40	13618	1.92	12837	1.92	12617	1.94	11377	2.17	10072	2.39	8732	2.31
42	42MRSE416D	860	1-1/2	34	12652	1.11	11225	1.20	10818	1.23	8962	1.39	6854	1.45	4878	1.53
	42MRSE422D	860	2	35	15940	1.87	14457	1.94	14135	1.97	12296	2.16	9854	2.23	8138	2.36
	42MRSE428D	860	3	41	19022	3.02	16901	3.08	16411	3.11	14000	3.24	11987	3.24	10384	3.44
	42MRSE424D	1140	5	56	22508	5.06	20859	5.16	20590	5.20	19390	5.41	18173	5.63	16079	5.80
48	48MRSE418D	680	1-1/2	29	15902	1.25	14073	1.35	13613	1.39	10571	1.56	7806	1.65	-	-
	48MRSE618D	680	2	27	16967	1.53	15630	1.68	15198	1.73	12898	1.97	10597	2.09	8594	2.20
	48MRSE426D	680	3	33	21262	2.55	19116	2.69	18499	2.72	14742	2.81	12325	2.97	9834	3.23
	48MRSE616D	860	3	39	18438	2.29	17188	2.60	16889	2.65	15394	2.83	13708	3.11	11916	3.26
	48MRSE620D	860	5	44	24258	4.06	22929	4.28	22599	4.33	20945	4.60	19237	4.87	17408	5.11
	48MRSE628D	860	7-1/2	52	30090	7.19	28979	7.16	28636	7.17	26157	7.52	23411	7.97	21492	8.09
	48MRSE414D	1140	5	69	22253	4.08	20729	4.20	20397	4.24	18851	4.47	17342	4.79	15696	5.18
	48MRSE618D	1140	7-1/2	71	28444	7.19	27749	7.44	27561	7.51	26500	7.85	25220	8.22	23762	8.62
	48MRSE424D	1140	10	75	33487	9.80	31433	9.93	31099	9.99	29654	10.29	28326	10.61	26878	10.94
54	54MRSE414D	680	2	32	18851	1.55	16249	1.68	15685	1.73	12613	2.00	9138	2.04	5967	2.19
	54MRSE616D	680	3	33	20704	2.03	18943	2.35	18521	2.40	16322	2.62	13787	2.88	11192	2.98
	54MRSE426D	680	5	39	30195	4.57	27838	4.78	27184	4.83	23176	5.00	19469	5.09	17010	5.41
	54MRSE418D	860	5	48	28561	4.53	26907	4.63	26507	4.68	24494	5.05	22173	5.47	19118	5.65
	54MRSE424D	860	7-1/2	59	35876	7.55	33129	7.72	32679	7.78	30659	8.12	28418	8.47	24901	8.70
	54MRSE624D	860	10	75	39150	9.95	37273	10.04	36863	10.11	34964	10.53	33141	11.05	31198	11.59
	54MRSE624D	860	10	55	43828	10.62	42476	10.89	42123	10.94	40250	11.11	38176	11.14	35855	11.09



LOREN COOK COMPANY

2015 E. DALE STREET
SPRINGFIELD, MO 65803-4637

417.869.6474

FAX 417.862.3820

lorencook.com