

1. Verify that all of the following parts have been shipped:

Part Name	Number of Parts
• Curb Latch Plate . . . . .	1
• Hinge Plates (1 Left 1 Right) . . . . .	2
• Aircraft Cable (72") . . . . .	1
• Cable Clamps . . . . .	2
• Bolts 5/16 x 1 1/2 . . . . .	2
• Bolt 5/16 x 3/4 . . . . .	1
(to secure latch in closed position)	
• Nut 5/16 . . . . .	1
(to secure latch in closed position)	
• 1/4 x 3/4 Kwik Drill screws . . . . .	8
• Wood Screws 1 1/2" . . . . .	16
• Pop rivets (retrofit only) . . . . .	2
• Base Latch Plate (retrofit only) . . . . .	1

2. Place the hinge plates on the curb as shown. The edge of the hinge plate should be flush with the edge of the curb. The 1/2" tapped rod should extend past the edge of the curb approximately 3/8". Before fastening the second hinge plate, verify that the distance between the left tapped rod and the right tapped rod is approximately 1/4" less than the inside dimension of the base. Secure in place with the wood screws provided.

3. Standard Installation:

- Place fan on curb with hinge holes in base aligned with tapped rod on hinge plate.

Retrofit Installation Below:

- Drill 3/8" diameter hole through base, on the left and right side of base as shown below.

4. Insert 5/16 x 1 1/2" bolt through hole in base and thread into tapped rod on hinge plate.

5. Insert 5/16 x 1 1/2" bolt through hole on opposite side in base and thread into tapped rod on hinge plate.

6. Tighten both bolts until the shank of the bolts bottom out in the threaded rod.

7. Standard Installation:

- Lift fan up far enough to get the curb latch plate into position.
- Align the left hole of the curb latch plate with the slot on the right of the base latch plate.
- Secure the curb latch plate with the wood screws provided.

Retrofit Installation:

- Center the base latch plate on side of base as shown.
- Mark location of holes on housing base using the latch plate as a template.
- Drill 7/32" diameter holes through base using the template. (Below)
- Secure base latch plate to base using pop rivets provided. Pop rivets should be inserted from inside the base through the latch plate.
- Lift fan up far enough to get the curb latch plate into position.
- Align the left hole of the curb latch plate with the slot on the right of the base latch plate.
- Secure the base latch plate with the wood screws provided.

8. Assemble the aircraft cable and clamps as shown. The cable length should allow the fan to pivot just past the balance point. If cable does not allow fan to pivot far enough to stay open, loosen one cable clamp and adjust cable length as necessary.

(TEMPLATE)

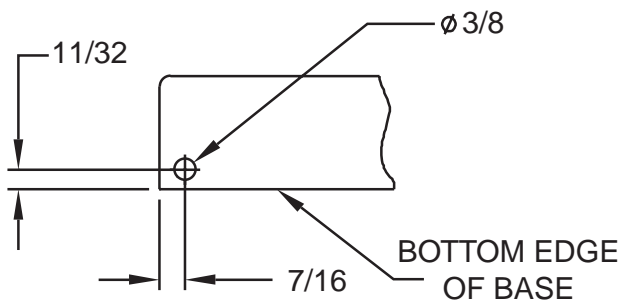

LEFT SIDE OF BASE

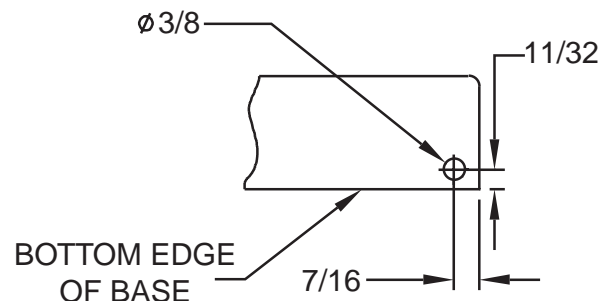

RIGHT SIDE OF BASE

# Hinged Base Supplemental Installation Instructions (continued)

## Installation on Curb with Wood Nailer (Figure 1)

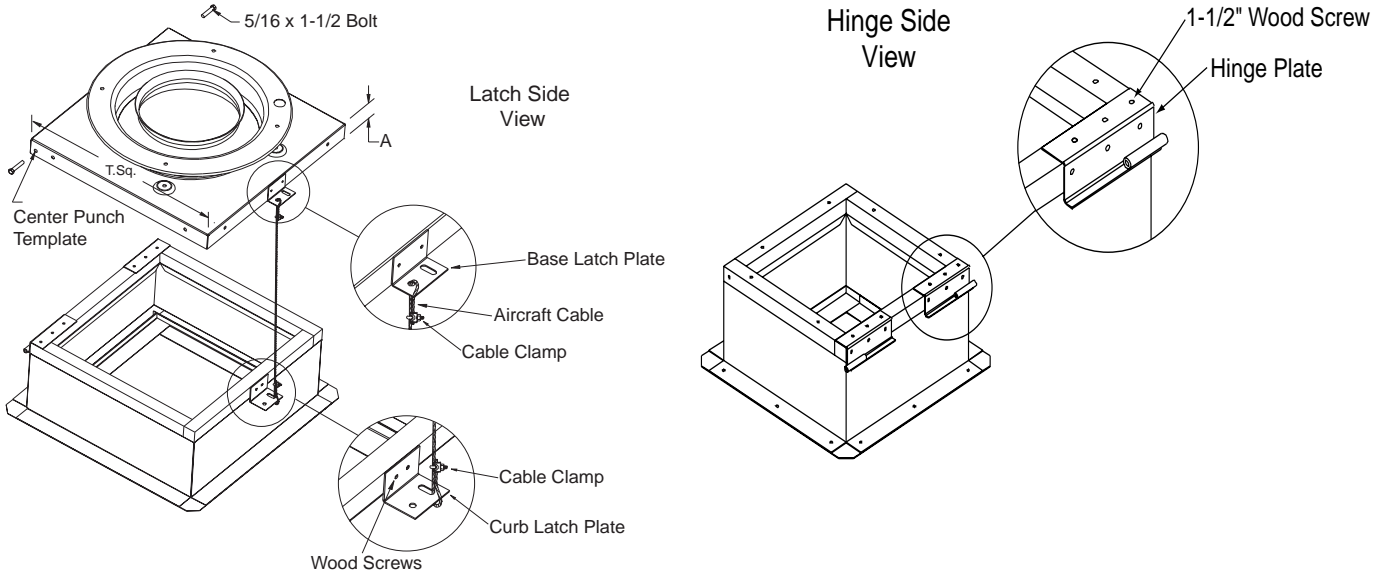

## Installation on Vented Extension or Curb without Wood Nailer (Figure 2)

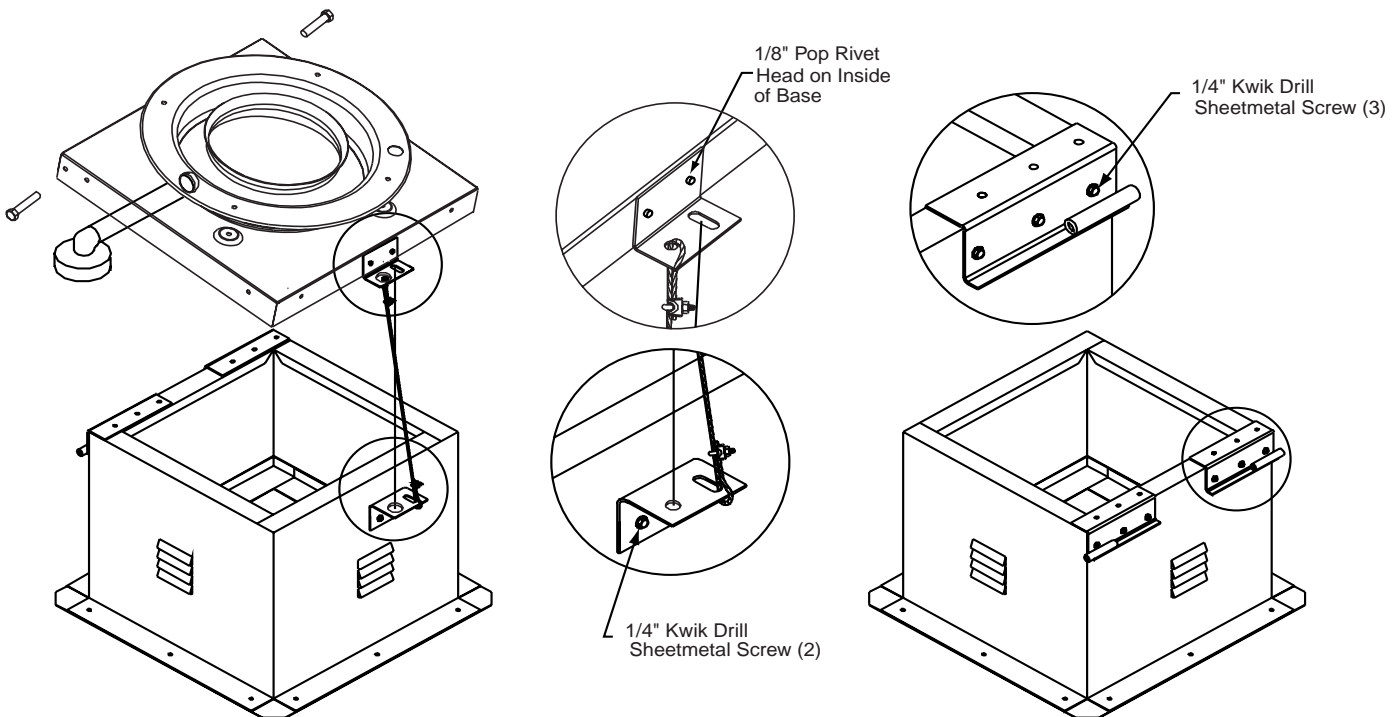

# LOREN COOK COMPANY

Corporate Offices: 2015 E. Dale Street Springfield, MO 65803 417.869.6474  
www.lorencook.com